

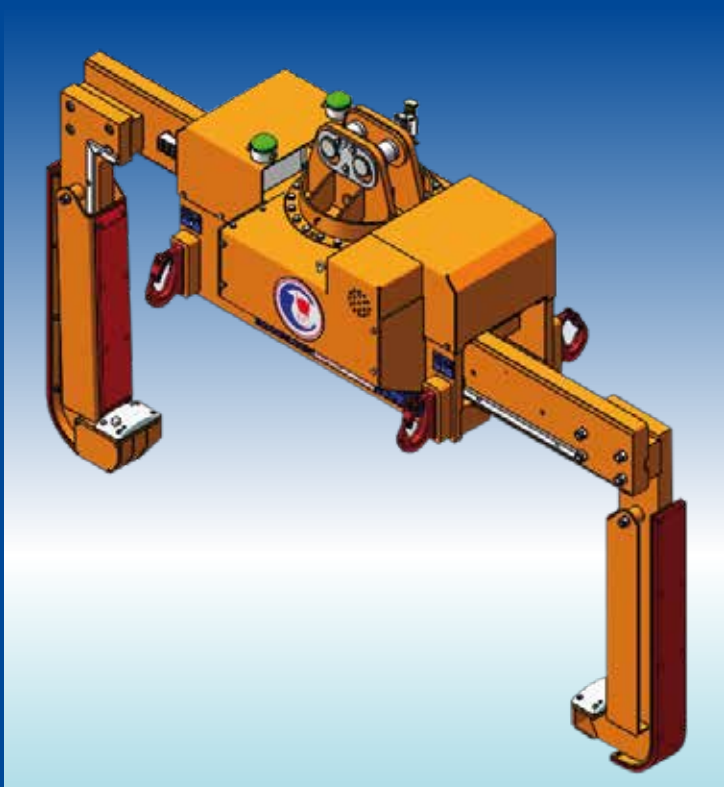

# COMAS<sup>s.r.l.</sup>

## NEW EQUIPMENT

Compact motorized gripper for horizontal coils

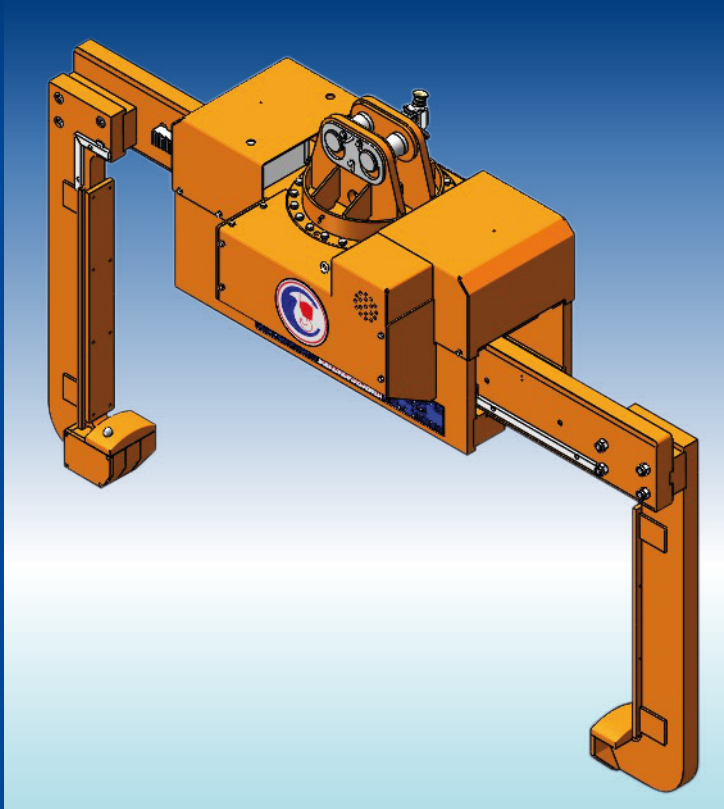

### STANDARD EQUIPMENT:

- Capacity up to 35t.
- FEM Class A6 M6.
- Rack and pinion drive.
- Integrated motorized rotation.
- Anti-opening sensors on the coil support.
- Maximum opening limit switch.
- Inclinometers with interlock on overhead crane.
- Support and transport included.

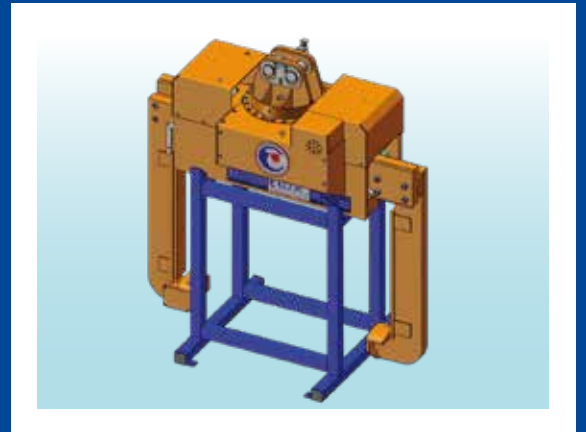

### APPLICABLE OPTIONS:

- "Industry 4.0" Module With Weighing System.
- Side Sensors With Translation Interlocks On Overhead Crane.
- Luminous Dome For Sensor Status Signaling.
- Photocell For Centering The Coil Hole.
- Jaw Coverings In Wear-resistant Steel Or Aluminum.
- Internal Polyurethane Jaw Linings.
- External Polyurethane Lining Of The Jaws.
- Latch Pin With Spring Safety.

